



Operating Manual

English



English

Important remarks concerning the manual

English

This operating manual makes use of the following icons to indicate especially important comments:

Remarks

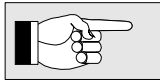

Information and tips which are important for optimal use of the OxySpy.

Attention!



Indicates information about details which are important to prevent a risky situation.

Danger!



Indicates a potentially hazardous situation which, if not avoided, could result in death or serious injury.

The following symbols are used in the operating manual:



LCD display samples

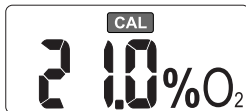

Grey or red: part of the display actually being described

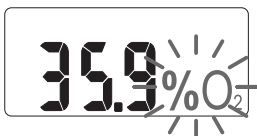

Flashing part of the display

List of chapters

Introduction	4
Warnings and Safety Considerations	5
OxySpy Parts List	6
The OxySpy	6
Set Up Procedure / Maintenance	
Before first use	6
Switching the OxySpy on and off	7
Opening the OxySpy	7
Fitting the O ₂ sensor	8
Fitting the battery	10
Calibration	11
Measurement	14
Service Indications / Trouble Shooting	
CAL symbol is displayed	16
O ₂ sensor not connected	16
O ₂ sensor symbol is displayed	17
Battery symbol is displayed	18
O ₂ % indication not stable in the air	18
O ₂ sensor	19
Maintenance and Storage	20
Operational limits	20
Technical Information	20
Limited Warranty	21
Notes	22
FCC / Copyright © / Waste disposal	23
Warranty paper	24

Introduction

The OxySpy is a portable Oxygen Analyser for the trained and certified mixed gas diver. The OxySpy can be held directly against the slightly opened diving tank and displays within seconds the oxygen percentage of the gas.

By pressing the push button the display can be frozen. By pressing the push button once more the maximum operation depth (MOD) is displayed. The calibration of the OxySpy is as easy: The unit detects itself whether the calibration is made in air or with pure oxygen. A calibration can only be terminated if the O₂ percentage does not change during the calibration.

If the OxySpy is not used, it switches off automatically.



Thanks to its ergonomical design and its single button operation, it can be operated by one hand.

The OxySpy displays the sensor or battery symbol, if the O₂ sensor or the battery are used up. Both are easily changed by the user.

Warnings and Safety Considerations

Important safety considerations



- If you are unsure about the displayed O₂ percentage: Repeat the measurement or check the value with another system. For measurements after filling the tank and before diving always use two different measuring units.
- Check the OxySpy in air before each series of measurements. If necessary, calibrate the OxySpy. See page 5.
- Using pure oxygen or oxygen enriched gas needs special safety measures! Please consider the general safety considerations of using pure oxygen or oxygen enriched gases!
- If the O₂ sensor symbol is shown, the displayed values can be wrong.
- If the diver uses the wrong value of the gas mixture he/she or the dive computer could calculate insufficient decompression time (EAD etc.) or oxygen toxicity (MOD, CNS% etc.). Both situations could result in death or serious injury.
- The maximum partial pressure of oxygen (ppO₂ limit) necessary for the calculation of the maximum operation depth (MOD) should not exceed 1.6 bar (the max. value for sports divers). Higher values may result in death or serious injury.
- Avoid risky situations which are marked in the this manual with  and .
- Do not use the OxySpy in pressure chambers.
- Do not submerge the OxySpy in water.
- The battery and the O₂ sensor contain corrosive liquid. If the battery or O₂ sensor leaks: Do not let the liquid come into contact with skin, eyes or mouth. If it does, flush the affected area with water for at least 15 minutes. Consult a doctor. Do not inhale vapor. Immediately clean the leakage from the instrument with a soft towel and dispose of the towel.

OxySpy Parts List / The OxySpy / Set Up

- OxySpy
Parts List
- 1 OxySpy with case
 - 1 OxySpy Operating Manual
 - 1 Battery CR 2430
 - 1 O₂ Sensor in a sealed package
 - 1 Philips-type Screwdriver

English

The OxySpy

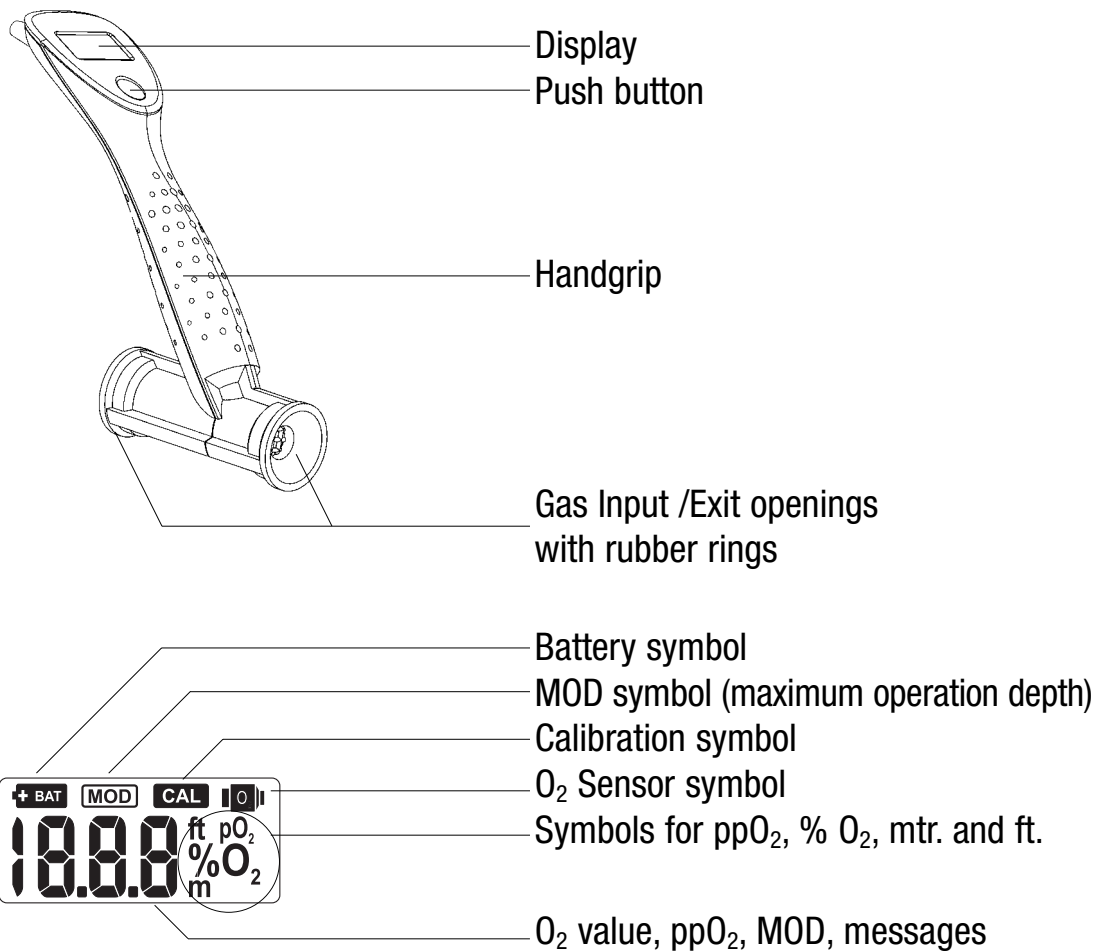

Before first use

The supplied battery and the O₂ sensor have to be fitted. Similar to the finite life of a battery, the O₂ sensor has a certain lifetime. From the first time that a O₂ sensor contacts oxygen it starts to be used up. To keep the lifetime of the O₂ sensor, its airtight package should only be opened before the sensor is used the first time.

Set Up Procedure / Maintenance

Switching on and off

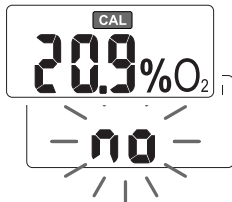

After a short push on the button, the OxySpy will display the measured O₂ percentage. If need be, the unit indicates that it requires calibration or indicates that no O₂ sensor is connected.

The OxySpy switches off automatically, at the latest 30 minutes after switching on. The unit cannot be switched off manually.

English

Opening the Oxy-Spy



- Open the OxySpy only in a clean and dry area away from water, dust and other contaminants. It prevents soiling and damage to the electronics and the mounting ring.
- Open the OxySpy only if the battery or the O₂ sensor must be replaced.
- Do not touch the electronics.

1. Pull the rear rubber ring off the housing.

2. Remove the 7 screws with the enclosed screwdriver and separate the two parts of the housing.

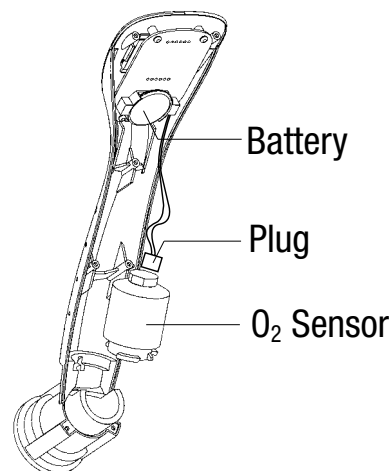
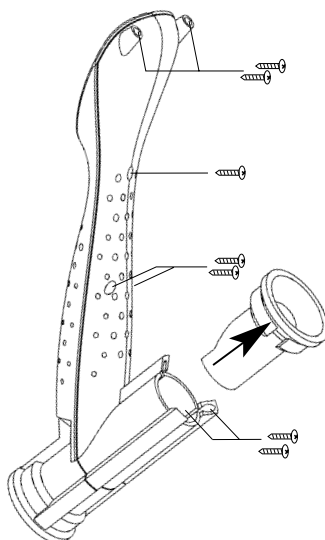

Set Up Procedure / Maintenance

Fitting the O₂ Sensor



1. Open the rear side of the housing according to the chapter "Opening the OxySpy" (page 7).

Consider the safety considerations on page 5 and the ones on the O₂ sensor and its package.

English

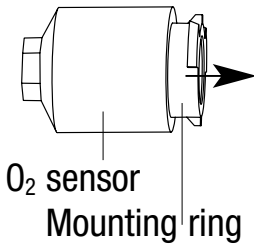

2. Take the O₂ sensor (if there is already one) out of its position and pull off the mounting ring.

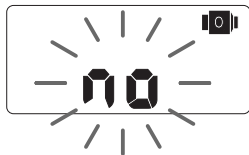

If the O₂ sensor is disconnected while the unit is on, the display shows the word "no" and the O₂ sensor symbol.

In this situation the OxySpy switches off after 5 minutes automatically.

3. Carefully pull the plug out of the socket. The tab, which stops the plug from being disconnected, has to be pulled back while pulling out the plug.

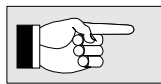

Do not pull on the wires!

- Do not open the airtight container before you need to use the O₂ sensor.
- After opening the sealed package the O₂ sensor needs 30 minutes start-up time. This means that calibration cannot be made until 30 minutes after opening the package. See "Calibration" page 11.
- Take care of the environment; properly dispose of used O₂ sensor! The sensor should be disposed of according to local laws.

Set Up Procedure / Maintenance

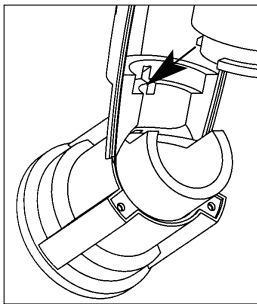
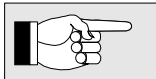
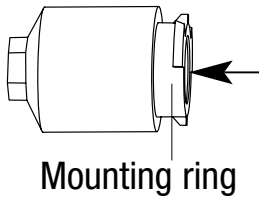

4. Take the new O₂ sensor out of its package. Take the O ring off the O₂ sensor (if there is any O ring).

Attach the mounting ring by twisting it onto the O₂ sensor, exactly as shown in the picture on the left. Maneuver until it fits snugly.

Write the date of the fitting onto the O₂ sensor.

5. Insert the plug into the socket of the O₂ sensor. Make sure that the tab, that secures the plug, is back in place. The lug of the mounting ring must fit into the notch of the housing.

6. If a battery is mounted: Switch the unit on and check that the display is on.

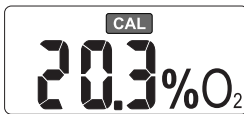

The unit will show the CAL symbol, because the OxySpy requires calibration. The displayed O₂ percentage may be incorrect.

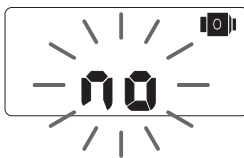

If "no" and the O₂ sensor symbol is displayed check the chapter "Trouble Shooting", page 16.

7. Carefully refit together the 2 parts of the case. Make sure that none of the wires get trapped and damaged by the case. Take care that the two parts fit together well and carefully tighten the 7 screws.

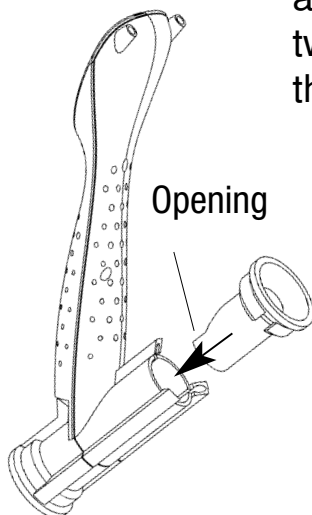

8. Locate the rubber ring into the housing so that its opening does not close the gas flow to the O₂ sensor.

9. Calibrate the OxySpy or fit a new battery. See "Calibration" or "Fitting the Battery" on page 11 or page 10, respectively.

Set Up Procedure / Maintenance

English

Fitting the battery

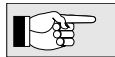
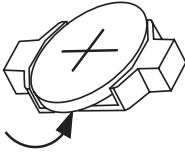

1. Open the rear side of the housing according to the chapter "Opening the OxySpy", (page 7).



Consider the safety considerations on page 5.

2. Pull the battery (if there is any) out of the battery holder, by hooking a finger under the battery.

Take care of the environment: Dispose of the used battery properly!

3. Wait a minimum of 2 minutes before installing the battery. Check that it is the correct type of battery (see "Technical Information" page 20). Press the battery into the battery holder until it snaps in place (+ on the top). The battery holder prevents an incorrect fitting.

4. Switch the unit on and check if the display is on. If the unit cannot be switched on, repeat step 2 and 3.



Choose the correct depth unit (mtr. or ft.) to display the maximum operation depth (MOD) by quickly pressing the push button.

To confirm the depth unit press the push button for at least two seconds.



Check the chosen metric system before refitting the parts of the case!

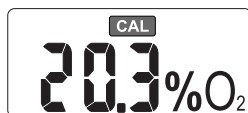

The unit will show the CAL symbol, because the OxySpy requires calibration. The displayed O₂ percentage may be incorrect.

5. Carefully refit together the 2 parts of the case. Make sure that none of the wires get trapped and damaged by the case. Take care that the two parts fit together well and carefully tighten the 7 screws.

6. Calibrate the OxySpy or mount a new sensor. See "Calibration" or "Fitting the O₂ sensor" on page 11 or page 8, respectively.

Calibration

What you have to know about calibration

The calibration can be made either in air (20.9%O₂) or pure oxygen (100%O₂). The OxySpy will automatically detect which gas is being used for calibration.

The O₂ sensor measures the partial pressure of the oxygen and the OxySpy calculates the O₂ percentage (O₂%) from it. Changes of the ambient pressure or temperature will influence the O₂ measurement values. This is the reason why the OxySpy has to be calibrated frequently. Once the O₂ sensor has been calibrated, the maximum allowed partial pressure of oxygen (ppO₂ limit) can be set. This value is needed by the OxySpy to calculate the maximum operation depth (MOD).

A new calibration is required when:

- The measured O₂ percentage in the air is below 20.7%O₂.
- The measured O₂ percentage in the air exceeds 21.1%O₂.
- The CAL symbol is displayed.
- If you are unsure about the displayed O₂ percentage.

The O₂ percentage of the gas mixture (used for the calibration) must not change during the calibration.

The duration of an OxySpy calibration is a maximum of 30 seconds.

The calibration can be interrupted at any time by pressing the button.



In hot or humid climates, the OxySpy should be calibrated either in pure oxygen (100%) or in compressed air from a tank.

Calibration

Calibrating in air



English

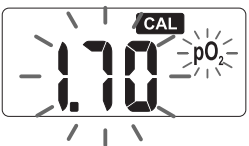
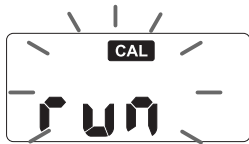

1. Before the calibration of the OxySpy in air (20.9%O₂) it has to be moved slowly back and forth, through the air, for about 1 minute to flush the O₂ sensor. Without this flushing, the calibration may not be successfully completed. Do not blow through the OxySpy as the CO₂ in your breath would cause an incorrect calibration.

2. Press the button until "CAL" and "run" appear. "CAL" and "run" will flash during the calibration. Move the OxySpy back and forth, slowly, during the entire 30 second calibration.

3. After the O₂ sensor has been calibrated, the OxySpy will display the ppO₂ limit (necessary for calculating the MOD). By quickly pressing the push button the setting may be changed in the range of 1.2 to 1.8 bar, displayed in 0.05 bar increments.

To confirm the indicated ppO₂ setting press the push button for at least 2 seconds.

If neither changes nor confirmations are made within 30 seconds, the OxySpy automatically switches back to the default setting of 1.4 bar.

If the selected ppO₂ limit is higher than 1.6 bar, the ppO₂ symbol will flash to warn the diver.

- The maximum partial pressure of oxygen (ppO₂ limit) for calculating the maximum operation depth (MOD) should not exceed 1.6 bar (the max. value for sports divers). Higher values may result in death or serious injury.
- For strenuous dives or diving in cold water the chosen ppO₂ limit should not exceed 1.4 bar.

The OxySpy switches automatically into the normal measurement mode.

Calibration

Calibrating with pure oxygen

The OxySpy can also be calibrated with pure medical oxygen (100% O₂).



- Please consider the general safety considerations of using pure oxygen!
- The calibration gas has to be 100% medical oxygen.
- At the gas input make sure that there is a good seal and that air cannot be sucked in.

The calibration procedure with pure oxygen is similar to the one described in the chapters "Calibrating in air" (page 12) and "Measurement" (page 14).

After the pure oxygen calibration: "Flush"(move it back and forth slowly) the OxySpy for 1 minute in air and check the indicated value. The value must be between 20.7 and 21.1%O₂. If not, redo the calibration.

Calibration was not successful

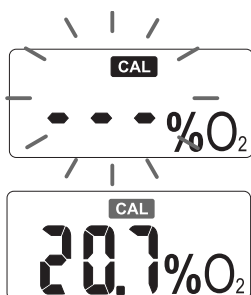

If the calibration has not been successfully completed or the calibration has been interrupted by pressing the button switch, the display will show a "- - -", for a short time. The OxySpy will then change automatically into the measurement mode. No new calibration values have been entered and the indicated O₂% values are still based on the old calibration data. The CAL symbol is displayed to inform you about the unsuccessful calibration.

Repeat the calibration if the CAL symbol is still displayed after the calibration. Several calibrations without success could be an indication that the O₂ sensor needs to be replaced or a fluctuation of the mixture of the calibration gas during the calibration. The fluctuation of the gas mixture might have been caused by air leaking in at the gas input due to a bad seal.

Measurement

What you have to understand

English



Consider the following points if you measure with the OxySpy:

- The gas must be able to flow through both elastic rings without resistance.
- Check the OxySpy in air before each measurement by "flushing" it (moving it back and forth for 1 minute in the air). If the displayed value is not between 20.7 and 21.1% O₂, the OxySpy has to be calibrated.
- The OxySpy must have a steady stream of the gas until the displayed O₂% value has stabilized.
- At the gas input (the rubber ring) make sure that there is a good seal and that air can not be sucked in.

Procedure to measure on diving tanks

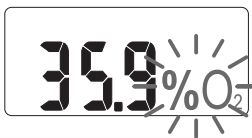

1. Press one of the two rubber rings against the tank valve.
2. Open the valve until you hear a gentle, uniform hiss and wait until the displayed O₂% value has stabilized.
3. "Freeze" the display by briefly pressing the push button. For confirmation the "%O₂" starts flashing.
4. Close the tank valve.

Measurement

5. If the displayed value does not match with your expectation, repeat the measurement or calibrate the OxySpy. See "Calibration" page 11.

6. Record the results of your measurement.



7. After quickly pressing the push button, the OxySpy will calculate the MOD based on the measured O₂ values and the chosen ppO₂ limit. The indicated maximum operation depth will be rounded to 0.1 mtr. or 1 ft.

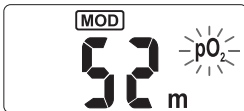

If the selected ppO₂ limit is higher than 1.6 bar, the ppO₂ symbol will flash to warn the diver.

8. By pressing the push button once more the OxySpy returns to measuring mode.

Repeat the measurement until you are sure that you measured the actual oxygen percentage of the gas mixture.

Service Indications / Trouble Shooting

The CAL symbol is displayed

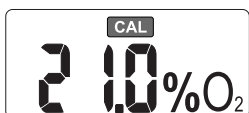

If the CAL symbol appears, the OxySpy has to be calibrated. The displayed O₂% value could be wrong.

Possible reasons:	How to solve:
New battery has been installed.	Calibrate the OxySpy. See page 11
New O ₂ sensor has been installed.	Calibrate the OxySpy. See page 11
Calibration was not successful.	Calibrate the OxySpy. See page 11

English

The O₂ sensor not connected

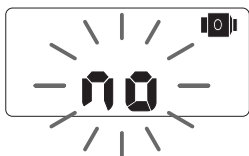

If the OxySpy does not "see" an O₂ sensor, the display shows "no" and the O₂ sensor symbol.

Possible reasons:	How to solve:
No O ₂ sensor connected	Install an O ₂ sensor and plug in. See "Fitting the O ₂ sensor", page 8.
Water in the housing	Remove the battery and the O ₂ sensor. Dry the case with a towel and warm air (max. 50 °C / 122 °F).
Plug or wire defect	Take the OxySpy to the store that it was purchased from.
Electronic defect.	Take the OxySpy to the store that it was purchased from.

Service Indications / Trouble Shooting

The O₂ sensor symbol is displayed

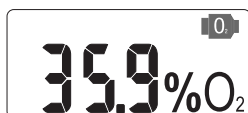

If the O₂ symbol appears, the indicated O₂% value could be incorrect.

Possible reasons:

How to solve:

The ambient air pressure is exceptionally low. (for example in high altitude)

At high altitudes the O₂ sensor symbol could be displayed by mistake. If the O₂ sensor symbol had not been displayed before ascending (to the higher altitude), than it is almost certain, that the low ambient pressure of the altitude is the reason for displaying the O₂ sensor.

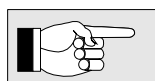

Check the OxySpy before ascending to altitude.

The O₂ sensor is used up

Replace the O₂ sensor. See "Fitting the O₂ sensor", page 8.

Water in the housing

Remove the battery and the O₂ sensor. Dry the case with a towel and warm air (max. 50 °C / 122 °F).

Electronic defect.

Take the OxySpy to the store that it was purchased from.

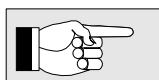

The O₂ sensors are available at OxySpy sales points. There is more information, regarding the O₂ sensor, on page 20.

English

Service Indications / Trouble Shooting

The Battery Symbol is displayed

At a low battery voltage, the OxySpy shows the battery symbol.



If the battery symbol appears, the indicated O₂% value could be wrong.

Possible reasons:

How to solve:

Extremely low temperature

Warm up the OxySpy and check again.

The battery is weak.

Replace the battery. See page 10.



English

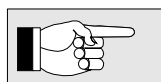

The battery is sold in camera and electronic stores. For more information about the battery, refer to page 20.

O₂% indication not stable in the air

The displayed oxygen percentage of the air goes up and down, even if the actual percentage does not change.

Possible reasons:

How to solve:

After a measurement of an O₂ enriched gas, the high concentration of oxygen in the OxySpy has first to be reduced.

"Flush" (move it back and forth) the OxySpy in air for approximately 30 seconds. Try to measure again.

O₂ sensor is defective or used up.

Replace the O₂ sensor.

The indicated O₂-value is inaccurate

The measured O₂-value deviates from the actual O₂-content by more than 1 or 2 percent.

Possible reasons:

How to solve:

The OxySpy has been calibrated in extremely humid air.

Calibrate the OxySpy in pure oxygen (100%) or in compressed air from a tank!

O₂ Sensors

The O₂ sensors have, like batteries, a certain lifetime. From the first time that a sensor contacts oxygen it starts to be used up. They can be replaced by the user (see "Fitting the O₂ sensor", page 8).

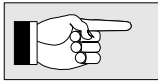

Disconnecting the O₂ Sensor from the socket does not extend its life. On page 20 you will find more information about storing the OxySpy.

After opening the airtight package the O₂ sensor requires 30 minutes to stabilize in air. Calibration should be made only after this "warm-up" time.



The battery and the O₂ sensor contain corrosive liquid. If the battery or O₂ sensor leaks: Do not let the liquid come into contact with skin, eyes or mouth. If it does, flush the affected area with water for at least 15 minutes. Consult a doctor. Do not inhale vapor. Immediately clean the leakage from the instrument with a soft towel and dispose of the towel.

Maintenance and Storage

- Maintenance and Storage**
- Protect the unit from impact and intensive sun and heat.
 - Store the unit in a cool, not too dry place. This helps to preserve the O₂ sensor life.
 - Ideal storage temperature: 5 °C up to +15 °C (41 °F up to 59 °F)
 - Do not leave the OxySpy in an oxygen enriched atmosphere except when it is necessary.
 - Disconnecting the O₂ Sensor from the socket does not extent its life.
 - Replace the battery and O₂ sensor early.
 - Do not clean the unit with any solvent (except water) or detergent.
 - Clean the OxySpy with a damp, soft towel.
 - Dry the instrument with a soft towel.
 - Do not scratch the display window.
- Operational limits**
- Maximum altitude: 4000 m (13,000 feet) above sea level
 - Temperature range: 0 °C up to +50 °C (32 °F to 122 °F)
 - Relative air humidity: 10-90%, non-condensing
- Technical Information**
- O₂ Display: • Resolution: 0.1% O₂
• Display range: 0.0 up to 199.9%O₂
 - O₂ Sensor: • Type Dynatron P/N DiveceL3.D1 or other O₂ sensors if licensed by the manufacturer.
• Lifetime: minimum 1 year*
 - Battery: • Type: CR2430
• Lifetime: min. 3 years at 500 on/ off cycles per year
 - Linearity: <3% (at constant pressure and temperature)

* Lifetime depending on environment conditions and the used product.

Limited Warranty

Please pay attention to the following remarks on warranty claims:

Recognition of warranty

The limited warranty only covers units which were purchased from an authorized retailer.

Scope of warranty

The manufacturer will repair all defects which are due to faulty materials or workmanship. The warranty covers the repair of the unit, free of charge. This includes the repair or replacement of the faulty part or the replacement of the entire OxySpy. The O₂ sensor, the battery and the rubber rings are excluded from the warranty. The manufacturer reserves the right to determine the merits of the warranty claim and to determine whether the unit will be repaired or replaced.

Excluded are faults or defects due to:

- improper operation or stress
- exterior influences, e.g. shipping damage, impact, damage due to bumping and hitting
- water damage
- influences of weather or other phenomena
- repairs preformed or attempted by unauthorized service agencies
- pressure chamber tests

Warranty period and claim:

The warranty is given for a period of two years after original date of purchase. Repairs or replacements during the warranty period do not extend the warranty period. In order to submit a warranty claim, deliver the unit, along with dated proof of purchase, to your authorized retailer or an authorized service location.

Please confirm that you have read the complete manual.

Place:

Date:

Signature:

English

Notes

English

FCC / Copyright ©

FCC

This device complies with part 15 of the FCC Rules. Operation is subject to the following two conditions: (1) This device may not cause harmful interference, and (2) this device must accept any interference received, including interference that may cause undesired operation.

Copyright ©

Copyright © 2003 by Dynatron AG

All rights reserved. No portion of this manual may be reproduced, processed or distributed in any form (print, photocopy, electronic or any other process) without prior, written permission from Dynatron AG.

Waste disposal



Protect the environment!

When disposing of this OxySpy, do so in an environmentally friendly way.

Return old products to an appropriate collection point according (EU Directive 2002/96/EC).

The OxySpy must not be placed in the normal household waste.

Warranty paper

Stamp of the
dealer:

English

Date of Sale:

Serial No. of
your OxySpy:

www.oxyspy.biz



Operating Manual OxySpy / OS-M-GB-B Rev.A

Printed in Switzerland 09-2006